

## PULLOUT TESTING OF CONCRETE

### Historical Background and Scientific Level Today



Herbert Krenchel, Dr.techn.,  
Department of Structural Engineering, ABK,  
Technical University of Denmark, DTH, Denmark

John A. Bickley, ACI-fellow,  
Concrete technology consultant for the Trow  
Group Ltd., Brampton, Ontario, Canada.  
Member of ACI committees: 214, 228 and 362.



### ABSTRACT

A survey of the different pullout systems developed for controlling concrete strength with an examination of stress- and strain-distribution inside the concrete at peak load by the Scandinavian pullout testing system.

Key words: pullout testing, compressive strength, fracture mechanic, internal micro-cracking, acoustic emission activity.

## 1. INTRODUCTION

Concrete pullout tests are considered non-destructive. The part of the concrete structure damaged by the test is normally so small that it can be easily repaired. Furthermore, in many cases, it is not necessary to continue the test to final rupture. Testing can be terminated when the required strength level has been reached in the concrete in which case the test is fully non-destructive. Even in cases where inserts are loaded to failure they can generally be left in place and no sensible damage occurs to the structure.

Different pullout, pulloff or break-off systems have been developed over the years for determining concrete strength. In most cases these methods have not been scientifically developed and did not therefore produce a reliable correlation to the material property of primary interest to the building industry: the concrete compressive strength.

## 2. DEVELOPMENT

### 2.1 Russian Pullout Tests

During the years 1934-1938 intensive research was going on in the Soviet Union with the aim of determining the strength of concrete in completed structures. Several different systems were suggested, the simplest and most promising method, it now appears, being the pullout test system suggested by I. V. Volf, Charckov, and (almost simultameously) by O. A. Gershberg, Moscow, as described in

1938 by B. G. Skramtajev, /1/.

This method consists of embedding a specially shaped steel rod with a spherically thickened end into the concrete during casting, see Fig. 1. The steel rod has a diameter of 8 mm and the spherical end - 12 mm, the centre of the sphere being placed 44 mm below the concrete surface so that full length of the rod in the concrete is about 50 mm.

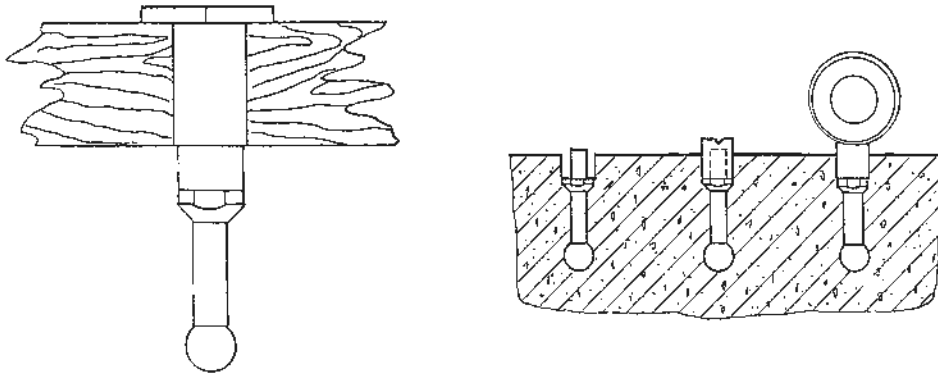

Fig. 1 Specially shaped steel rods with spherically thickened ends for the Russian pullout testing system (Volf and Gershberg, 1934/38).

Testing for concrete strength is carried out by pulling out the rod in its longitudinal direction vertically to the concrete surface by means of a special dynamometer placed on the concrete surface. In this way a cone of concrete is pulled out with the rod, the top of the cone laying nearly in the centre of the sphere and with generating lines starting at an angle of approximately 45 degrees to the axis of the bolt, but running out near the concrete surface to a maximum diameter of about 10-12 cm, see Fig. 2 and 3.

Volf carried out series of experiments to determine the relation between the concrete cube strength  $R_c$  and the maximum load at rupture  $P$  (the pulling effort). In 1938 such calibrations had only been carried out with very low strength concrete ( $R_c$  from 1.5 to 10.8 MPa). These tests showed a simple linear correlation between  $P$  (in kg) and  $R_c$  (in kg per sq.cm):  $K = \frac{P}{R_c} = 9.5$ .

Experiments with higher strength concrete would have shown whether the coefficient  $K$  remains a constant or varies with the strength of the concrete. Such test results have, as far as is known, not been published. From the principle of this test system and from the shape of the rupture cone as shown in Fig. 3, it seems clear that the pullout force  $P$  in these tests must have been more directly related to the concrete *tensile* strength than to the compressive strength. With this test system the coefficient  $K$  will decrease drastically with increasing concrete compressive strength. It is not likely that it would be possible with normal types of concrete (compressive strength  $\sigma_c$  between

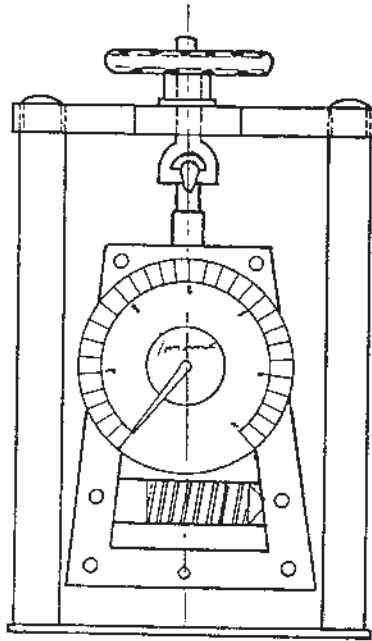

Fig. 2 Special dynamometer for pullout tests according to Fig. 1.

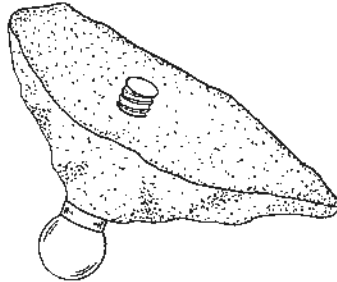

Fig. 3 Steel rod and concrete cone from pullout test according to Fig. 1 and 2.

20 and 50 MPa f.inst.) to predict indirectly with any reasonable confidence the compressive strength of the material from this type of pullout tests.

## 2.2 Pulloff Test By Glueing

Some thirty years ago different types of two-component epoxy glue came on the market. These are very efficient cold setting organic cements ideal for fixing metal components directly to a concrete surface f.inst. The adhesion properties of this glue or cement far exceed the tensile strength of even the strongest type of Portland cement concrete. At several laboratories, all over the world, different test systems were suggested and tried out on this basis.

A disc or stiff plate was glued onto the concrete surface and pulled or broken off later, when the glue had set.

Such tests have been mentioned sporadically in the literature from time to time since then. It seems that there is only limited interest in this testing principle today because of the high scatter in the test results obtained and the poor correlation which is always found in such tests between the pulloff load and the concrete compressive strength, see Fig. 4. (The results are no doubt more directly correlated to the concrete *tensile* strength).

### 3. POST WORLD WAR II DEVELOPMENT

In the 60's and 70's renewed interest in pullout testing was created by the works of Kaindl, Kierkegaard-Hansen, Malhotra, Richards, and Tremper.

#### 3.1 Pullout Testing With Steel Disc

During the years 1960-70 P. Kierkegaard-Hansen (Denmark) developed the so-called LOK-TEST method, a pullout testing system giving a reliable in-situ determination of the concrete compressive strength.

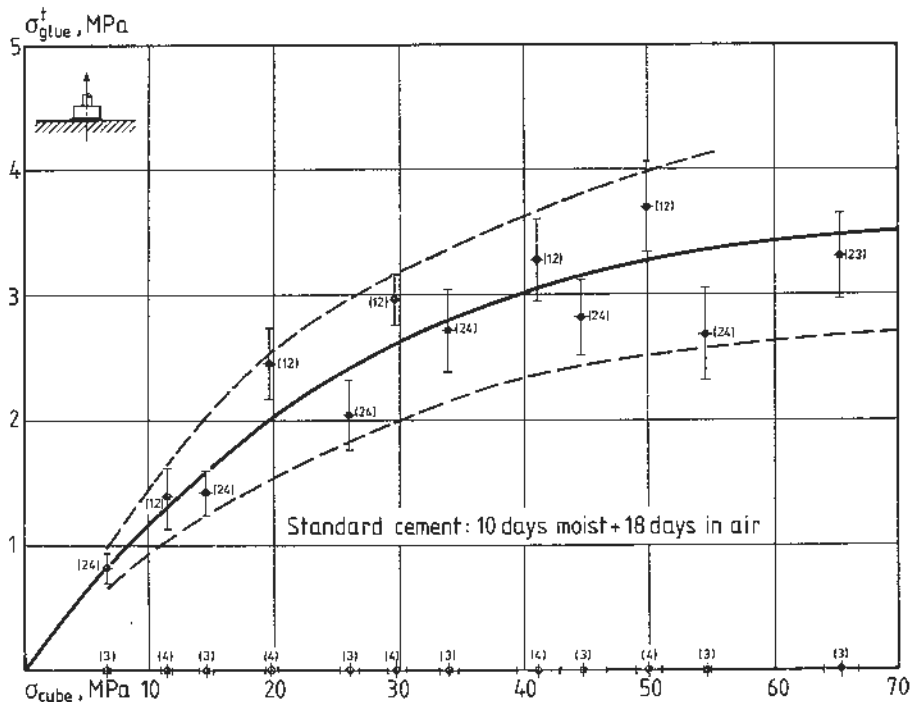

Fig. 4 Results from pulloff tests by glueing. (Efsen and Krenchel, 1953/54).

This test system has some resemblance with the old Russian method by Volf and Gershberg, but it is of a better design giving no premature failure inside the concrete at the head of the pullout bolt and, further, what is a significant improvement, the top angle of the rupture cone has been chosen so that a direct linear relationship is obtained with close correlation between the pull-out force and the concrete compressive strength.

With this system a thick 25 mm circular steel disc (1) is fixed by a special bolt (2) and screw (3) on the inside of the form before casting the concrete. The bolt or stem holds the disc at a distance of 25 mm from the inside of the form with its axis perpendicular to the concrete surface, see Fig. 5.

Just before stripping the form the screw (3) is loosened so that disc and bolt stays inside the concrete.

On the day of testing the bolt (2) is replaced by a 7.5 mm bolt of high-tensile steel and a small 7 tons capacity hydraulic jack is placed on the concrete surface and connected to the tensile bolt. The jack rests on the concrete surface and applies force through a counter-pressure ring. The inside diameter of this ring and the outside diameter of the steel disc determine the geometry of the final pullout cone.

When Kierkegaard-Hansen carried out his first tests according to this system some twentyfive years ago, the inside diameter of the counter-pressure ring in his first test set-up was substantially bigger than today (130 mm instead of 55 mm). The calibra-

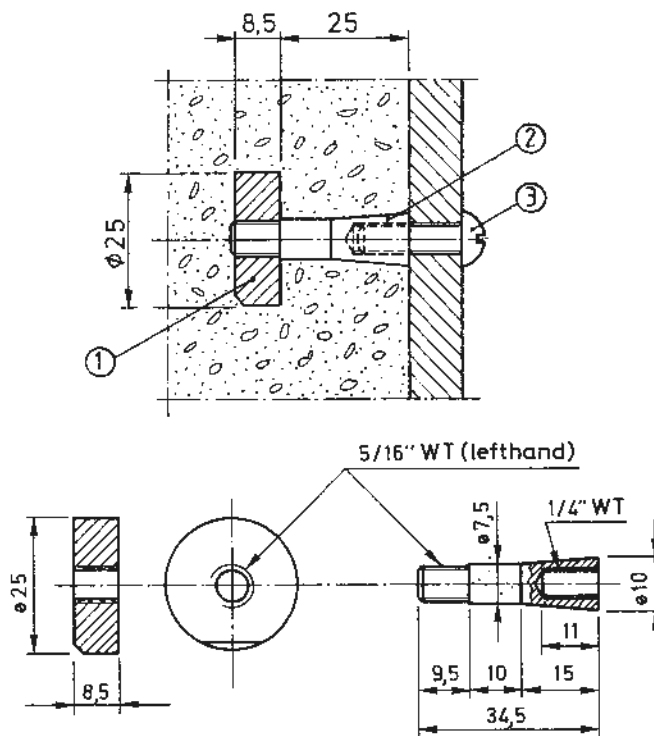

Fig. 5 Pullout disc and bolt fixed on inside of form before casting the concrete.

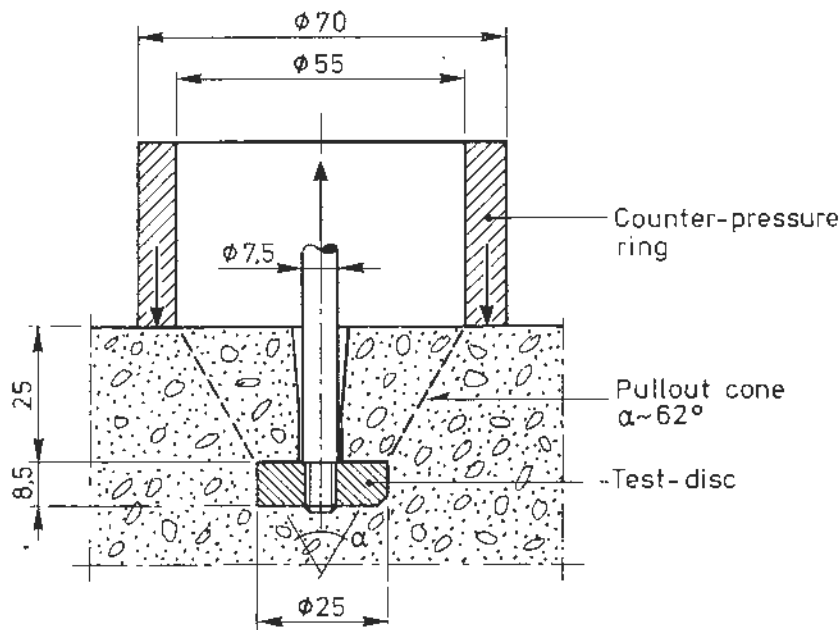

Fig. 6 Test set-up for the so-called LOK-TEST pullout system. (Dimensions in mm).

tion curve he then obtained between pullout force and concrete quality showed more or less direct correlation to the concrete *tensile* strength as with the pulloff testing systems mentioned above. By systematically reducing the inside diameter of the counter-pressure ring step by step keeping all other dimensions fixed he finally found that a direct correlation to the concrete *compressive* strength is obtained when the top angle of the pullout cone is about  $62^\circ$ , see Fig. 6.

### 3.2 Further Development

A draw-back with the above system, is that it can only be used where the special test discs have been cast into the concrete beforehand. In order to be able to use the system after casting the concrete, C. Germann Petersen (Denmark) seven years ago developed the so-called CAPO-TEST.

The principle here is that a hole 18 mm diameter and about 45 mm deep is first drilled in the concrete perpendicularly to the surface. After this a groove is cut out in the concrete with a special milling equipment. This groove has a diameter of 25 mm and is 10 mm high. It is formed 25 mm below the concrete surface, see Fig. 7.

A special expanding steel disc with an outside diameter of 18 mm is then placed on a bolt and put into the hole down to the level of the groove. By turning the bolt with two wrenches (the bolt consists of an inside and an outside part) the steel disc is expanded, until it reaches the inside diameter of the groove, see Figures 8 and 9. Finally the pullout jack mentioned above is placed in top of the equipment and connected with the pull

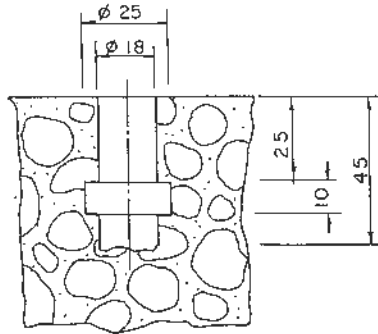

Fig. 7 Hole and groove drilled out for the so-called CAPO-TEST pullout system. (Dimensions in mm).

bolt. A pullout test is then made in the same way with the same system, the same geometry inside the concrete, and with the same top angle in the pullout cone.

### 3.3 Correlation With Compressive Strength

In construction, the property of concrete which is required to be determined in order to remove forms, post-tension, remove shores, or terminate curing is the compressive strength of the concrete. Since it is universally accepted that the compressive strength of the concrete is determined by testing standard specimens (cylinders or cubes) it is necessary for any non-destructive test system used to be correlated with the standard test specimens so that the answer obtained by the non-destructive test is a measure of the compressive strength of the concrete in place.

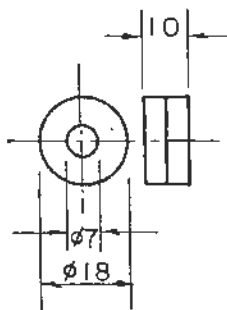

Fig. 8 Special expanding steel disc for the CAPO-TEST system. (Dimensions in mm).

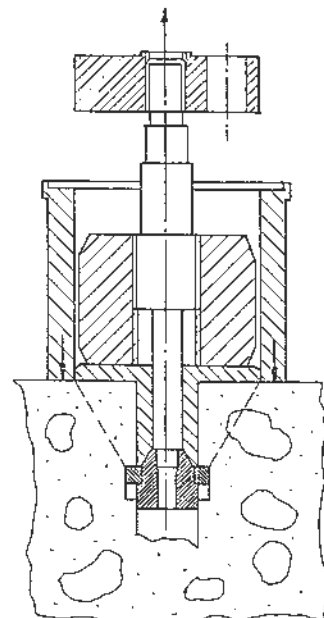

Fig. 9 Test set-up for the CAPO-TEST system.

The pullout system mentioned has been intensively examined since then by several laboratories all over the world, /2/, /3/, /4/, (with most relevant references from the period). It is interesting to see what little influence the different parameters such as type of cement, type of aggregate and curing conditions have on the calibration curve, the spread in the test results, and the coefficient of correlation.

For concrete with a compressive strength (determined on 150 × 300 mm test cylinders) from 15 MPa to 85 MPa (maximum capacity of the instrument) the calibration curve is linear and a coefficient of correlation of between 0.90 and 0.95 is normally obtained. Even major changes in the curing conditions have shown practically no influence on the position of the calibration curve.

The linear calibration curve in combination with the high coefficient of correlation indicates that rupture at pull-out loading in this test system is caused by the compression straining in the truncated area between the top face of the steel disc and the bottom face of the counter-pressure ring.

On the basis of, say, five tests carried out on a given sample of concrete the compressive strength of the material is predicted with a maximum deviation of ± 4 MPa (95% confidence limits). If twenty tests are carried out on the same concrete the deviation will be only ± 2 MPa.

### 3.4 Correlation Data

In 1979 large scale calibration tests were carried out at the Technical University of Denmark (Department of Structural Engineering) with both types of pullout methods in parallel /5/.

Thirty different test series were carried out with each of the two test methods, the concrete compressive strength (cylinders: 150 mm diameter × 300 mm) varying from 3.3 MPa to 74.0 MPa. The result of these calibration tests appears in Table 1, where  $\sigma_c$  is the average compressive strength of the concrete,  $v_\sigma$  the coefficient of variation and  $n_\sigma$  the number of compressive tests, on which  $\sigma_c$  and  $v_\sigma$  are determined.  $L$  is the average pullout load in each series of LOK-tests and  $C$  the average pullout load from the CAPO-tests,  $v$  and  $n$ , again, being coefficient of variation and number of tests in these figures, respectively.

It will be seen that for normal types of concrete (compressive strength above, say, 10 MPa) the coefficient of variation in the compression tests was between 2.3 and 6.6%, in the LOK-tests between 1.6 and 14.9% and in the CAPO-tests between 2.6 and 12.9%.

The calibration curves from these tests are shown in the diagrams Fig. 10 and 11. It will be seen that in both cases the curves are linear from a concrete compressive strength above 15 MPa. It will further be seen that the coefficient of correla-



Table 1 CALIBRATION TESTS BASED ON 128 COMPRESSION TESTS (cylinders 150 mm diameter x 300 mm), 240 LOK-tests and 234 CAPO-tests (Department of Structural Engineering, ABK/DTH, 1979)

Series No.	Compressive tests			LOK-tests			CAPO-tests		
	$\sigma_c$	$v_\sigma$	$n_\sigma$	L	$V_L$	$n_L$	C	$v_C$	$n_C$
	MPa	%	No.	kN	%	No.	kN	%	No.
1	28.2	3.1	4	28.7	5.4	8	29.1	6.4	6
2	28.8	2.4	4	30.6	8.3	8	30.0	7.9	8
3	30.8	3.3	4	30.6	6.9	8	30.9	8.2	8
4	30.5	5.5	4	31.3	8.3	8	31.1	10.7	8
5	29.5	3.5	3	33.1	9.1	6	32.3	8.6	6
6	29.4	6.6	3	33.5	6.7	6	32.7	7.8	6
7	14.3	5.0	6	14.9	7.7	12	13.0	9.4	12
8	42.6	3.4	6	39.1	6.4	6	40.6	6.3	6
9	44.2	2.7	6	39.2	6.7	6	39.7	4.6	6
10	42.6	3.4	6	38.8	3.2	6	39.8	3.4	6
11	44.2	2.7	6	38.5	4.3	6	37.9	3.4	6
12	25.4	5.0	6	22.7	7.3	12	21.1	6.1	12
13	37.4	2.3	2	33.0	6.5	4	32.8	2.6	4
14	39.1	3.6	2	35.3	1.6	4	35.1	5.5	4
15	40.2	1.2	2	32.8	5.7	4	30.9	9.3	4
16	40.2	4.0	2	32.0	9.2	4	31.9	6.1	4
17	38.1	4.6	3	35.1	13.0	6	35.8	9.5	6
18	38.6	3.8	3	34.2	7.1	6	35.8	5.4	6
19	32.9	3.8	5	26.9	8.5	12	26.9	8.5	12
20	33.0	3.1	6	30.0	5.6	12	29.1	10.1	12
21	28.8	4.5	4	22.4	14.9	8	25.8	10.8	8
22	26.3	4.1	4	22.7	12.0	8	24.2	7.1	8
23	24.9	3.6	4	22.6	9.8	8	22.9	4.9	8
24	24.7	3.6	6	21.8	6.0	12	21.2	12.9	12
25	42.8	3.1	2	31.8	8.3	4	34.4	8.7	4
26	39.3	3.1	2	31.3	6.2	4	31.8	4.6	4
27	37.1	4.0	2	33.8	7.4	4	35.4	4.7	4
28	74.0	3.5	9	61.6	6.7	24	60.6	5.7	24
# 29	7.6	3.0	6	8.66	11.9	12	9.04	13.4	12
# 30	3.3	2.6	6	4.71	16.6	12	3.44	22.7	8
	Mean	3.9			8.1			7.9	

Note: # This data not included in the weighted mean values as compressive strength range was below 15.0 MPa (see Fig. 10 and 11).

tion in both cases was quite high ( $r_{xy} = 0.95$ ) and that the regression line is practically the same<sup>xy</sup> for the two types of tests. With L and C in kN and  $\sigma_c$  in MPa the following results were obtained:

$$\text{LOK-TEST: } L = 4.7 + 0.768 \sigma_c \quad (s = 3.60)$$

$$\text{CAPO-TEST: } C = 5.3 + 0.751 \sigma_c \quad (s = 3.47)$$

where s is standard deviation of the residual.

#### 4 FRACTURE MECHANICS ANALYSIS

The extraordinary close correlation always obtained between the concrete compressive strength and the ultimate load in the LOK- and CAPO-TEST system has puzzled many researchers and put up the following questions: What is the fracture mechanics in the concrete when this type of testing is carried out? What happens inside the concrete when the pullout peak load is reached?

These problems have been examined in different ways over the years: by Jensen and Braestrup in 1976 (plasticity theory), /6/, by Ottosen in 1981 (nonlinear finite element analysis), /7/ by Stone and Carino in 1983 (large scale tests with embedded strain gauges in the concrete), /8/, and by Krenchel and Shah in 1985 (analysis of progressive micro crack formation with simultaneous examination of acoustic emission activity), /9/.

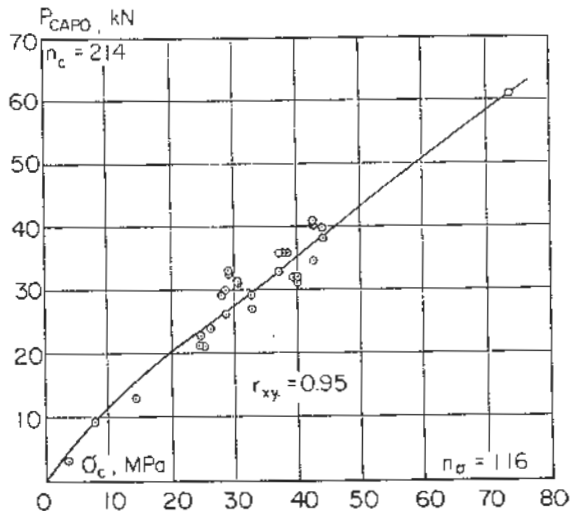
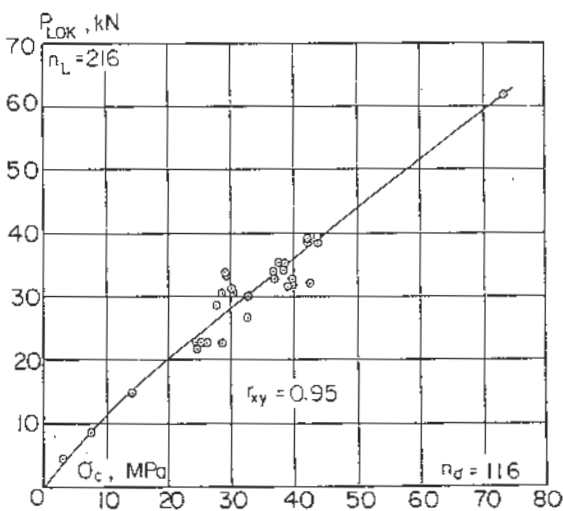

Fig. 10 and 11 Calibration curves from LOK-TEST and CAPO-TEST investigations carried out in 1979 (Technical University of Denmark, Department of Structural Engineering).

#### 4. CONCLUSION

The conclusion today from these theoretical and experimental examinations seems to be, that the internal rupture during this type of test is a multi-stage process, where three different stages with different fracture mechanisms can be clearly separated:

1. In the first stage, at a load level of about 30-40% of the ultimate load, tensile cracks are formed starting from the notch formed by the upper edge of the pullout disc. These cracks are running out in the concrete with a very open angle, (cone angle between  $100^{\circ}$  and  $135^{\circ}$ ). Total length of this first crack is typically some 15 to 20 mm from the edge of the disc, /10/.

As a result of this first stage cracking the material between the top face of the pullout disc and the bottom face of the counter pressure ring is now free so that straining in the material is now concentrated and all load is taken up in the truncated zone between these two plane faces.

2. In the second stage of internal rupture a multitude of stable microcracks are formed in the above-mentioned truncated zone, the main direction of these cracks running from top of disc to bottom of ring forming a cone angle of approximately  $84^{\circ}$ , see Fig. 12.

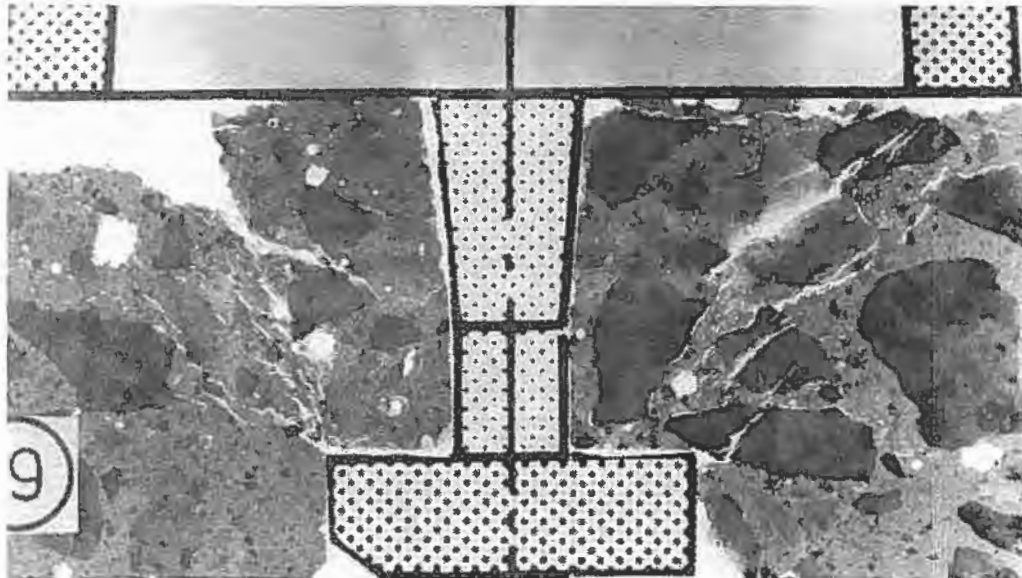

Fig. 12 Crack analysis of pullout test de-loaded from peak of load/displacement curve. Tensile cracking stage No. 1 is seen to the left and multi micro cracking stage 2 to the right. Pullout crack stage 3 has not yet been formed.

The formation of this second cracking pattern is very much parallel to the formation of more and more vertical micro-cracks inside a concrete cylinder or prism during ordinary uniaxial compressive tests, /11/, /12/.

Development of the acoustic emission activity during this second stage of the test also follows an exponential function quite parallel to the AE-development in ordinary uniaxial compressive tests, /9/.

If the pullout jack is specially equipped with transducers for measuring load versus displacement during the test, this second stage of internal microcrack formation could be followed all the way up to and just past the peak of the stress-strain curve.

2. If more and more oil is pumped to the pullout jack, even after the load has stabilized at the peak point, then the third stage of internal rupture occurs by the formation of a tensile/shear crack all the way round, running from the outside edge of the disc to the inside edge of the counter pressure ring and forming the final pullout cone with a cone angle of about  $62^\circ$ , see Fig. 13.

This is followed by a sharp jump in the AE-activity to a level approximately twice as high as it was at the peak of the stress-strain curve. This very high AE-level is kept

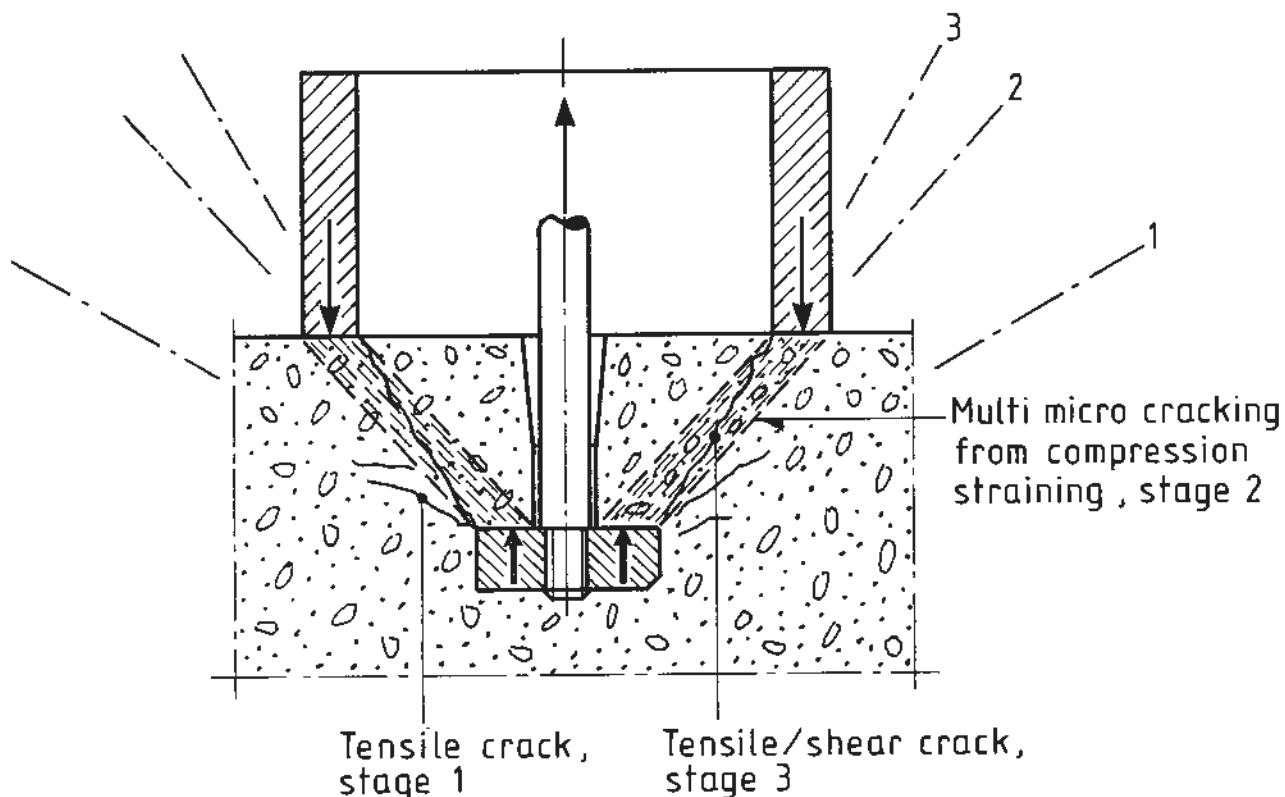

Fig. 13 The three different stages of internal cracking in the concrete during pull-out loading.

constant during the descending part of the stress-strain curve where the concrete cone and the disc is now pulled out.

In most cases of practical testing with this system the oil pressure in the pullout jack is released just after the peak of the stress-strain curve when the load just starts descending, but before the last mentioned type of crack has been developed. In this case the test is fully non-destructive.

As micro cracking stage No. two is responsible for and directly related to the ultimate load in this testing procedure it seems quite logical that such close correlation with the concrete *compressive* strength is always obtained.

It would be interesting one day to measure the ultimate compressive straining in the center-line of the truncated compression zone (with a cone angle of  $84^\circ$ ) and not in the shear zone (cone angle  $62^\circ$ ) where maximum compressive straining does not occur in this testing system.

Presumably most confusion regarding the scientific level of this testing system has been introduced by the name: Pullout Testing. If this test is carried out correctly with de-loading just after the peak load has been established, no pulling-out occurs. This is a parallel to what happens during ordinary compressive testing of concrete where the cube or cylinder can be taken out in one piece just after the peak load is

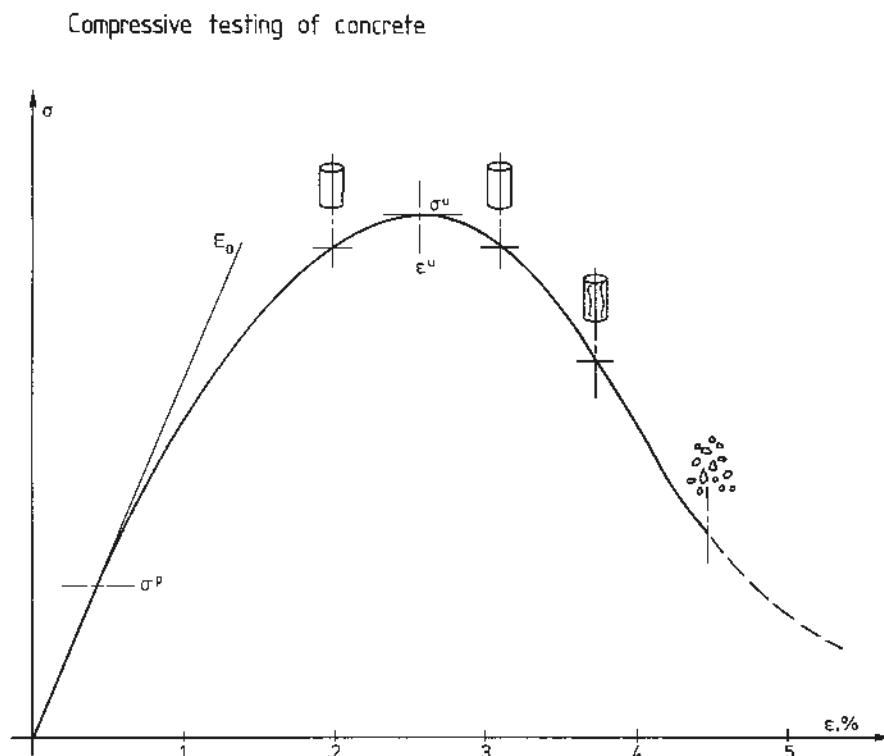

Fig. 14 Stress-strain curve from uniaxial compressive test on plain concrete.

passed. Total crushing of the concrete way down the descending branch of the stress-strain has nothing to do with the internal fracture mechanism at the peak point, where the compressive strength of the material is determined.

#### REFERENCES

- /1/ Skramtajev, B.G.: Determining Concrete Strength for Control of Concrete in Structures. ACI-Proceedings, Vol. 34, (1938), pp. 285-303.
- /2/ Bickley, J.A.: The Variability of Pullout Tests and In-place Concrete Strength. Concrete International: Design and Construction, Vol. 4, No. 4, Apr. 1982, pp. 44-51.
- /3/ Petersen, C.G.: LOK-Test and CAPO-Test Development and their Applications. Proc. Institution of Civil Engineers, Part 1, May 1984, pp. 539-549.
- /4/ Krenchel, H. and Petersen, C.G.: In-Situ Pullout Testing with LOK-TEST, Ten Years' Experience. Presented at the Research Session of the International Conference on In Situ/Non-Destructive Testing of Concrete, Ottawa, Ontario, October 2-5, 1984, pp. 24.
- /5/ Krenchel, H.: LOK-Testing and CAPO-Testing of Concrete Compressive Strength (in Danish). Department of Structural Engineering (ABK), Technical University of Denmark, Internal Report: I71, 1982.
- /6/ Jensen, B.C. and Bræstrup, M.W.: LOK-Test Determines the Compressive Strength of Concrete. Nordisk Beton, Journal of the Nordic Concrete Federation (Stockholm), No. 2, 1976, pp. 9-11.
- /7/ Ottosen, N.S.: Nonlinear Finite Element Analyses of Pullout Test. Proceedings, Journal of the Structural Division, ASCE, Vol. 107, ST4, Apr. 1981, pp. 591-603.
- /8/ Stone, W.C. and Carino, N.J.: Deformation and Failure in Large-Scale Pullout Tests. ACI Journal, Technical Paper, November-December 1983, pp. 501-513.
- /9/ Krenchel, H. and Shah, S.P.: Fracture Analysis of the Pullout Test. RILEM, Materials and Structures, Nov.-Dec. 1985, No. 108, pp. 439-445.
- /10/ Ballarini, P., Shah, S.P. and Keer, L.M.: Failure characteristics of short anchor bolts embedded in a brittle material. Proc. Royal Society of London A404, 8. March 1986, pp. 35-54.
- /11/ Glucklich, J.: Fracture of plain concrete. Proceedings of the American Society of Civil Engineers, Vol. 89, No. EM6, December 1963, pp. 127-138.
- /12/ Shah, S.P. and Slate, F.: Internal Microcracking Mortar-Aggregate bond and the Stress-Strain curve of Concrete. International Conference: The Structure of Concrete. Cement and Concrete Association, London 1965, pp. 82-92.